

VBX-150



Centrifugal Smoke extractor fan in steel housing

Wheel diameter: 150 mm

Power supply: 230 V, 50 Hz

Material: Fanblade – stainless steel
Motor shaft – stainless steel
Insulation class – «F»

Temperature range: -30 +90 °C

Temperature of the exhaust air: 250° C max.

Hall sensor



Type	Power input, W	Air flow, m ³ /h	Static pressure, Pa	Speed, min ⁻¹	Motor capacitor, μF	Weight, kg
VBX-150-2E-A-1	58	156	257	2668	1	5,1

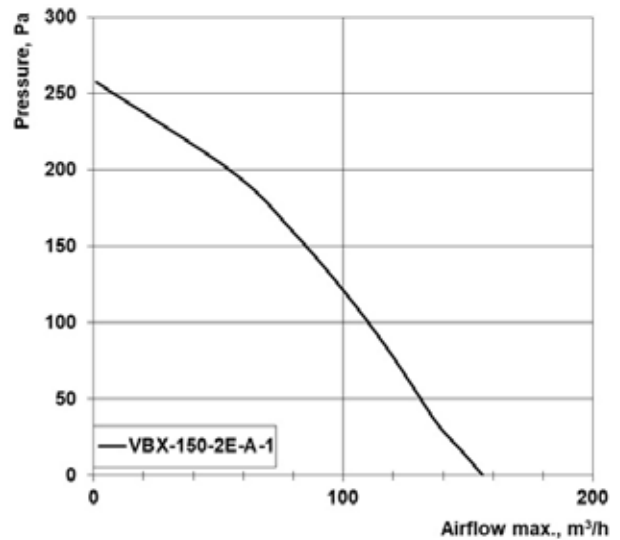
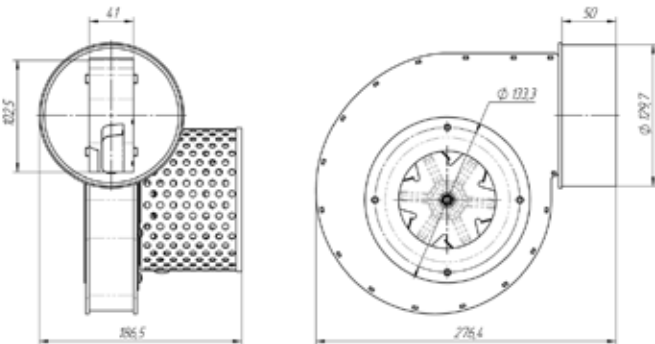

Additional options



Longer Cable

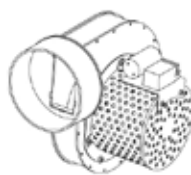

4PIN Socket



Terminal Socket

VBX-180



Centrifugal Smoke extractor fan in steel housing

Wheel diameter: 180 mm

Power supply: 230 V, 50 Hz

Material: Fanblade – stainless steel
Motor shaft – stainless steel
Insulation class – «F»

Temperature range: -30 +90 °C

Temperature of the exhaust air: 250° C max.

Hall sensor



Type	Power input, W	Air flow, m³/h	Static pressure, Pa	Speed, min ⁻¹	Motor capacitor, µF	Weight, kg
VBX-180-2E-A-1	40	300	250	2200	2	4,9
VBX-180-2E-B-1	77	404	387	2600	2	5,1

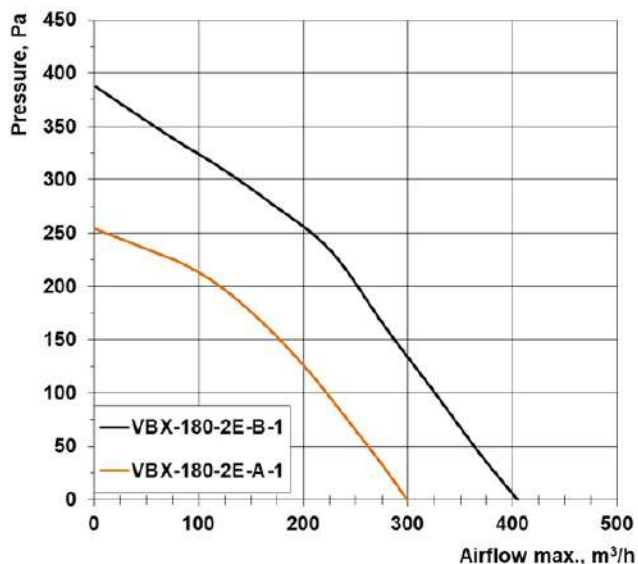
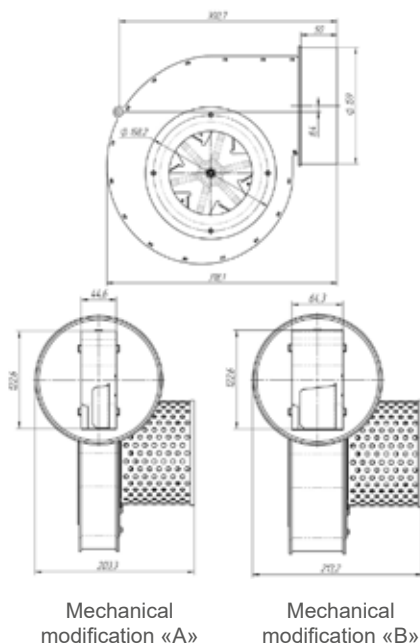

Additional options



Longer Cable

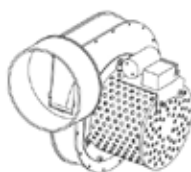

4PIN Socket



Terminal Socket